

MÜTRİDE



Hydro-Park 2236

High-end Four Post Parking Lift

PROFESSIONAL PARKING SOLUTION PROVIDER!

Hydro-Park 2236

Four Post Parking Lift 2 Levels

Introduction

Hydro-Park 2236 is the new Four Post Parking Lift designed by Mutrade based on old FPP-2. It's a kind of valet parking equipment, with electrical control system. It moves only vertically, so the users have to clear the ground level to get the higher level car down. It is hydraulic driven with steel ropes. The equipment can be used for heavy duty vehicles.

- Commercial grade design
- 3600kg capacity makes it possible for heavy duty vehicles.
- 2100mm usable platform width makes it much easier for parking and retrieve.
- Unique mechanical steel ropes detection will stop platform at once in case steel rope is loosen or cut off.
- Anti-slip diamond plates as drive way
- Lateral protection wings at two sides of platform will prevent vehicles going out.
- Electric key switch control for security and safety
- Automatic shut-off if operator releases the key switch
- LOCK DOWN button makes platform sit on locking tabs to increase safety and rest the cylinder for longer lifetime.
- Hydraulic cylinder and steel rope drive system for smooth operation
- The pole with piston is chroming to anti-corrode to ensure its long using life
- Self-standing and self-support structure
- Dynamic mechanical locks as anti-falling device hold the platform in place
- Platform can be stopped at different heights to fit for various vehicles and ceiling heights

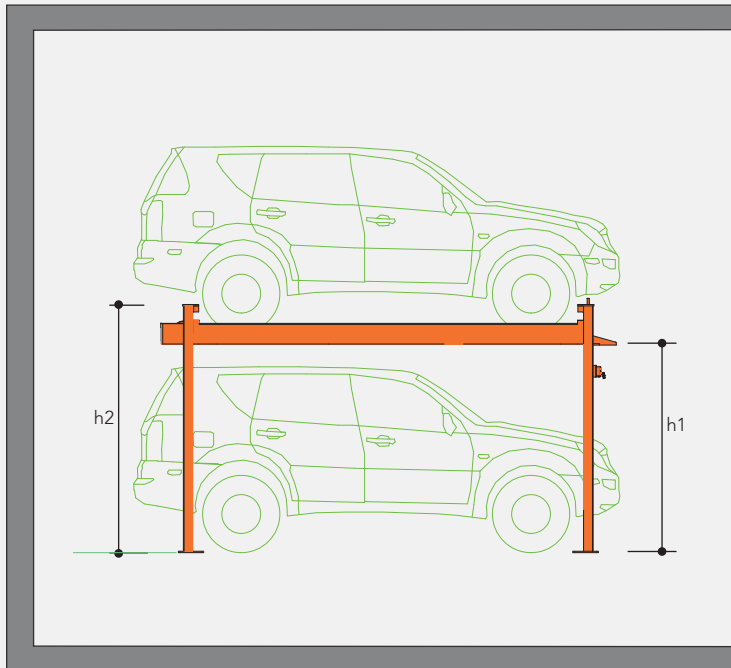

Hydro-Park 2236

h1(mm)	1800
h2(mm)	2226

General Parts



- 1 Top cover plate of post
- 2 Post
- 3 Lateral protection wing
- 4 Ramp
- 5 Cover plates
- 6 Wheel stopper
- 7 Drive way
- 8 Powerpack



- 1 Wider platform for easy parking**
The usable width of the platform is 2100mm with a total equipment width of 2540mm.
- 2 Strong and stable Structure**
4-Post design makes the structure stronger and more stable.
- 3 Dynamic locking device & break cable detection lock**
We are offering the safest parking machine in the market, the equipment is built under the CE standard and there are more than 10 safety features to ensure our clients will always get protection. Especially, there are a range of locking tabs on the posts to protect cars from accident damage.
- 4 Lock down button**
User could press LOCK DOWN button to make platform descend a little and sit on locking tab after platform go up to top position, to make cylinder "rest" without any pressure. Therefore the hydraulic cylinder could be used for longer time.
- 5 Low usage cost**
When the platform moves down, it will be driven by gravity, so there is no electricity consumption for hydraulic power pack.
- 6 Fast and easy installation**
With professional design and friendly package, it becomes simple on installation. What's more, detailed installation manual, drawing and video attached with products will help customers have easier installation work.
- 7 Professional packing & delivery**
We have very professional packaging and logistic people to ensure our customer will get the product damage free , simple load & unload in time.

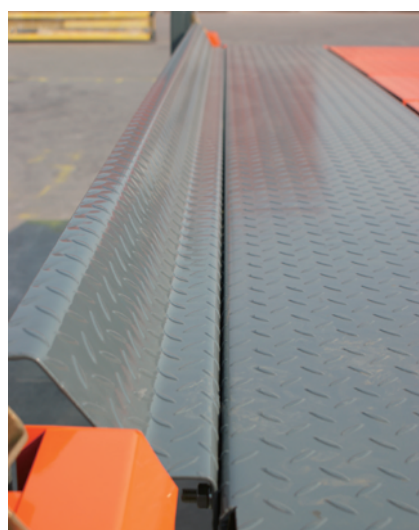
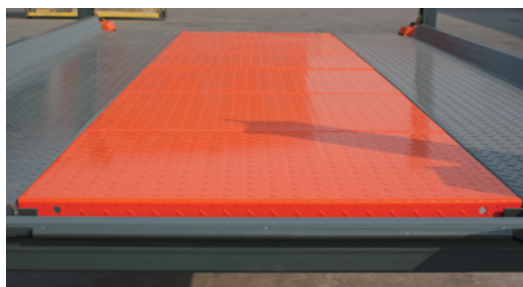

Specifications

Model	Hydro-Park 2236
Lifting capacity	3600kg
Equipment weight	800kg
Lifting height	1800mm
Usable platform width	2100mm
Electrical required	220-420V, 1 or 3Phase, 50/60Hz
Control power	24V
Lock device	Dynamic
Lock release	Electric auto release
Operation	Key switch
Power pack	2.2 kw
Lifting/lowing time	50/45 Sec.
Finishing	Powder coating

Drawing

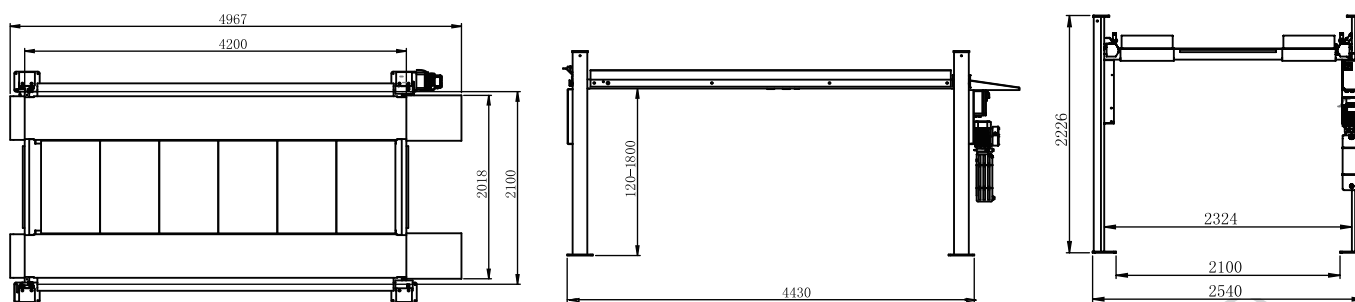

Safety Features

- "All the way" 11 mechanical safety lock every 10cm
- Unique mechanical steel ropes detection will stop platform at once in case steel rope is loosen or cut off.
- Lateral protection wings at two sides of platform will prevent vehicles going out.
- 24v electric lock release (no harm for operator)
- Electric protection for power over load or under voltage.
- Auto locking system for power cut as safety features.
- Emergency stop button.
- Pressure relief valve and pressure compensate flow control valve to tripe ensure safety.
- Limited switch on the main post, activated by platform (when the platform go to the appointed height, it will automatic stopped to avoid the wrong operation)
- Overload protection device for hydraulic power pack



Finishing



Powder coating is applied as a free-flowing, dry powder. It is typically applied electrostatically and is then cured under heat to allow it to flow and form a "skin". It is usually used to create a hard finish that is tougher than conventional paint.



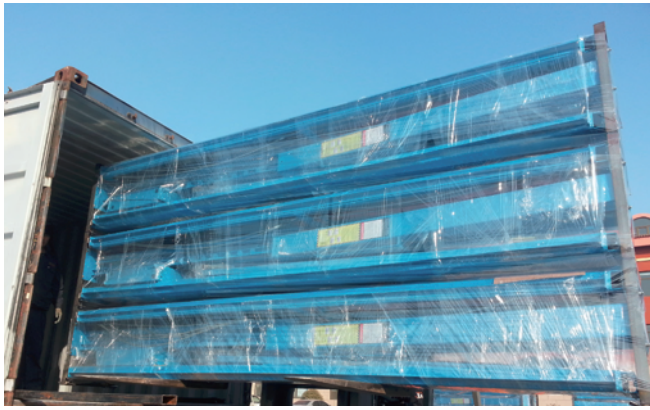

Model	Hydro-Park 2236
20 feet container	12 units
40 feet container	24 units

Q&A

- How many cars could be parked for each unit?
2 cars. One is on the ground and another is on the platform.
- Could Hydro-Park 2236 be used for parking SUV?
Yes, the rated capacity of Hydro-Park 2236 is 3600kg, so all SUVs can be available.
- Can Hydro-Park 2236 be used outdoor?
Hydro-Park 2236 is capable for both indoor and outdoor use. When used indoor, you need consider the ceiling height.
- What's the supply voltage?
Standard voltage is 220v, 50/60Hz, 1Phase. Other voltages could be customized according to clients' request.
- Is the operation easy?
Yes. Keep holding the key switch to operate the equipment, which will stop at once if your hand releases.

Warranty

Hydro-Park 2236 has a 5 years warranty on structure, and 1 years warranty for the whole machine. Within the warranty period, power units, hydraulic cylinders, and all other assembly components such as slip plates, cables, chains, valves, switches etc, are warranted for three years against defects in material or workmanship under normal use. MUTRADE shall repair or replace at their option for the warranty period those parts returned to the factory freight prepaid which prove upon inspection to be defective. MUTRADE will not be responsible on any labor costs unless pre-agreed. Mutrade will not responsible for the modification or upgrade of the product from the client unless pre-agreed.

These warranties do not extend to...

- defects caused by ordinary wear, abuse, misuse, shipping damage, un-proper installation, voltage or lack of required maintenance;
- damages resulting from purchaser's neglect or failure to operate products in accordance with instructions provided in the owner's manual(s) and/or other accompanying instructions supplied;
- normal wear items or service normally required to maintain the product in a safe operating condition;
- any component damaged in shipment;
- other items not listed but may be considered general wear parts;
- damage caused by rain, excessive humidity, corrosive environments or other contaminants.



- any change or modification made to the equipment without pre-agreed.

These warranties do not extend to any cosmetic defect not interfering with equipment functionality or any incidental, indirect, or consequential loss, damage, or expense that may result from any defect, failure, or malfunction of a MUTRADE product or the breach or delay in performance of the warranty.

This warranty is exclusive and in lieu of all other warranties expressed or implied.

MUTRADE reserves the right to make design changes or add improvements to its product line without incurring any obligation to make such changes on product sold previously.

Warranty adjustments within the above stated policies are based on the model and serial number of the equipment. This data must be furnished with all warranty claims.

Important notice

About the customized size:

If the size of the platform need to be customized based on customer require, difficulties might arise when entering or exiting the cars on the parking units. This depends on car type, the access and the individual driving behavior.

Operating device:

The position of the operating device depends on the project (switch post, house wall). From bottom of the shaft to the operating device an empty pipe DN40 with taut wire is necessary.

Temperature:

The installation is designed to operate between +5°and +40°C. Atmospheric Humidity: 50% at +40°C. If the lol circumstances differ from the above please contact MuTrade.

Illumination:

Illumination has to be considered acc. to local requirements by client. Illumination in the shaft for maintenance is required to be minimum 80 Lux.

Maintenance:

Regular maintenance by qualified personnel can be provided by means of an Annual Service Contract.

Protection against corrosion:

Independent of a maintenance workings has to be carried out acc. to MuTrade Cleaning and Maintenance Instruction regularly. Clean up galvanized parts and platforms of dirt and road salt as well as other pollution (corrosion danger)! Pit must be always ventilated well.

